

Simply
elegant



ergonomic & intuitive ●

single-handed operation ●

award-winning design ●





FIREPHANT by **NAPFIRE** is a uniquely-shaped powder fire extinguisher with an elegant touch. Its innovative and user-friendly design has clinched a Red Dot Design Award in 2012 (Swedish Industrial Designer: Jonas Forsman and Lars Wettre), transforming a life-saving fire safety product into a work of art.

Whether it is an eye-catching signal red or a minimalist discreet white, the aesthetic appeal of this exclusive top-class product lies in its perfect complement to any living area or kitchen, like a beautifully-crafted home accessory.

The handle is ergonomically designed for single-handed operation, comfortable for both left and right-handed users. It operates with just a simple push of a button.



As it is small, portable and lightweight, it is easy to manoeuvre, ideal for use in car or boat.

PATENTED WALL BRACKET

Simply hold the extinguisher in one hand and click into place. Release it quickly during emergency.





reddot design award
best of the best 2012



TECHNICAL DATA

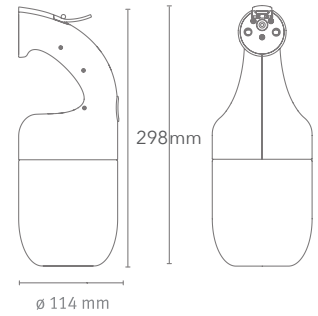

Fire class _____ A B C
Rating _____ 8A 34B C
Weight _____ 2380 g
Colour _____ Red or white
Certifications _____ CE, DIN EN3

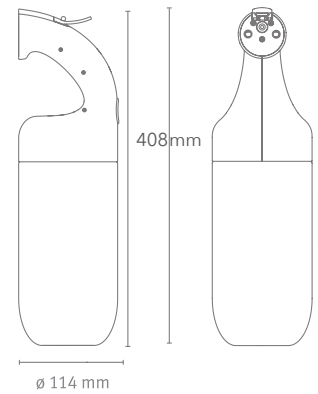

Fire class _____ A B C
Rating _____ 13A 89B C
Weight _____ 4200 g
Colour _____ Red or white
Certifications _____ CE, DIN EN3

Conveniently available in 1kg and 2kg, the **FIREPHANT** by **NAPFIRE** has ABC classification* and is fully certified by CE, DIN EN3.

The 1kg powder fire extinguisher can effectively put out small fires and complement to a 6kg powder extinguisher (Rating: 8A 34B C).

The 2kg powder fire extinguisher has the highest extinguishing power of its class and is useful for all kinds of fires where a 6kg powder extinguisher may be too big and heavy to handle (Rating: 13A 89B C).

PRODUCT & TECHNICAL INFORMATION

1 KG

Class Standard	CE, DIN EN3
Dimensions	298mm (H) x 114mm (OD)
Actual Product weight	2380 gram
Colours	Red or white
Fixture Option	Invisible wall mounted with fixing bracket - supplied
Features	Powder
Feature 2	Suitable for ABC classified fires
Feature 3	Suitable for one hand operation either left or right-handed users
Display	Manometer pressure display
1 kg Extinguisher Rating	8A 34B C
1 kg Extinguisher Capacity	Complement to a 6kg powder extinguisher
Usage area	Home, Offices, Kitchen, Car, Caravan, Boat

2 KG

Class Standard	CE, DIN EN3
Dimensions	408mm (H) x 114mm (OD)
Actual Product weight	4200 gram
Colours	Red or white
Fixture Option	Invisible wall mounted with fixing bracket - supplied
Features	Powder
Feature 2	Suitable for ABC classified fires
Feature 3	Suitable for one hand operation either left or right-handed users
Display	Manometer pressure display
2 kg Extinguisher Rating	13A 89B C
2 kg Extinguisher Capacity	Convenient, Dependable, Highest Extinguishing power of its class
Usage area	Home, Offices, Kitchen, Car, Caravan, Boat

*A-wood, paper; B-liquids, gas, solvent; and C-electrical fires.



For more information, please contact:

Ivan Yan

✉ ian@napco-offshore.com

☎ +65 9369 8048

Alvin Tan

✉ alvintan@napco-offshore.com

☎ +65 8338 0035

Adrian Png

✉ adrianpng@napco-offshore.com

☎ +65 9040 0930



Firephant[®]
DESIGNED FOR LIFE